

DKC500AC/DKC800AC Sliding Gate Opener User Manual

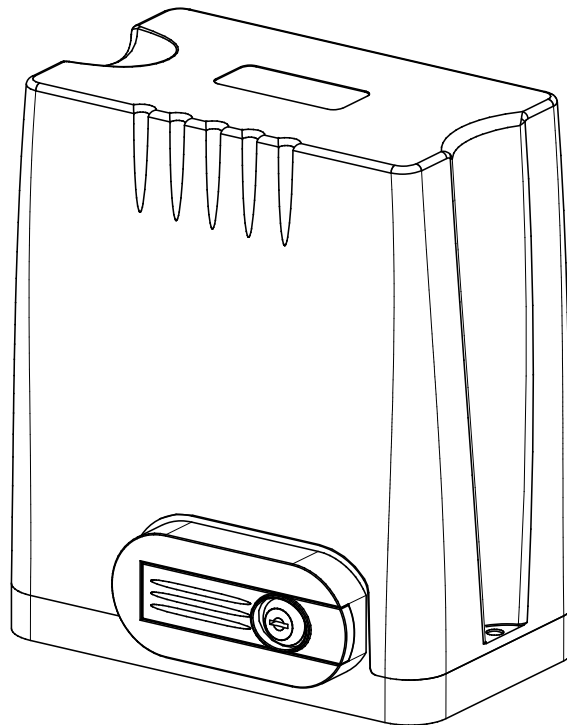

1. Safety Instruction:



Please read this manual carefully before installation, in which involves with important information about installation、 using、 maintenance and safety.

Any undefined operations under this manual is not allowed, incorrect using may damage the product even causing the injuries or property losses.

To consider the possible danger during the installation or using process of sliding gate operator, installation must strictly comply with the construction standard and Electrical operating procedure, especially the following:

Before installation, please make sure that the power voltage being used matches with the supply voltage of this product. Please check if the leakage protection switch is installed and the grounding system is correct.

Please check if additional equipments or materials are required to meet the specific requirements. The disposal of packaging material must be complying with the local regulation.

Please do not change any parts except for those defined under this manual. Any undefined changes may cause the malfunction. Any damages to the product arising therefrom shall be beyond the liability of the company.

Please do not leak water or any liquid into the controller or any other open devices. Please disconnect the power immediately if any mentioned cases happened.

Please keep this product away from heat and open fire. Or it may damage the components; cause the failure or other hazards.

Please make sure there is no vehicles、 passengers and objects passing through while the sliding gate is moving.

Anti-clip equipment like infrared protection switch must be installed to avoid injuries to person and property losses. The company shall not be liable for any damage or accident arising therefrom.



The installation、 using and maintenance of this product must be carried out by professionals.

Children are not allowed be touch the control devices or remote transmitters.

A warning sign must be placed somewhere on the sliding gate according to the national standard.

Please keep this instruction properly for future reference.

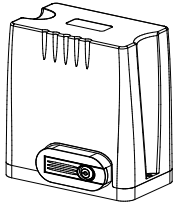
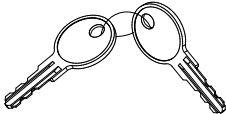
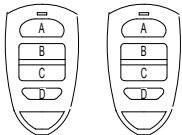
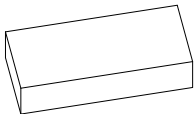
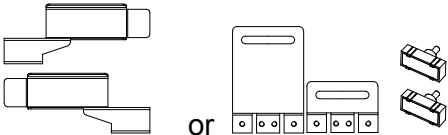
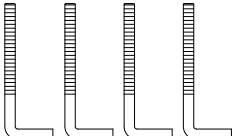
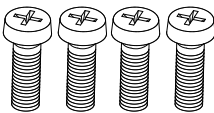
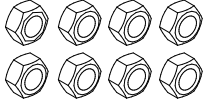
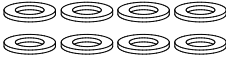
2. Packing List (standard)

No.	Picture	Name	Quantity
1		Main engine	1
2		Manual release key	2
3		Remote control	2
4		Spring limit switch accessories box / Magnetic limit switch accessories box	1
4-1		Spring limit switch block / Magnetic limit switch block	1
4-2		Foundation bolt M8	4
4-3		Spring limit switch block mounting screw M6X10 / Magnetic limit switch block mounting screw M6X18	4
4-4		Nut M8	8
4-5		Flat washer Ø8	8
4-6		Spring washer Ø8	4

2. Packing List (optional)

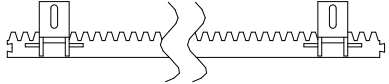
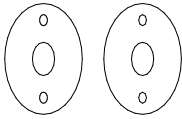
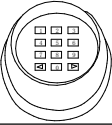
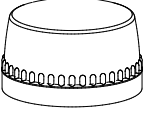
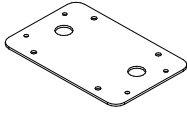
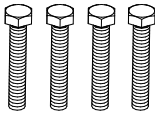
No.	Picture	Name	Quantity
1		Steel gear rack	1m/pc
2		Nylon gear rack	1m/pc
3		Infrared sensor	1
4		Wireless keypad	1
5		Alarm lamp	1
6		Mounting plate	1
7		Hexagon head bolt M8x60	4

3. Technical parameters

Model	DKC500AC	DKC800AC
Power supply	220V/50Hz;110V/60Hz	220V/50Hz;110V/60Hz
Motor power	280W	380W
Gate moving speed	13m/min	13m/min
Maximum weight of gate	600Kg	800Kg
Remote control distance	≥30m	≥30m
Remote control mode	Single button mode / Three button mode	Single button mode / Three button mode
Limit switch	Spring limit switch Magnetic limit switch	Spring limit switch / Magnetic limit switch
Noise	≤56dB	≤56dB
Working duty	S2, 20min	S2, 20min
Recording of up remote controls	25	25
Frequency	433.92 MHz	433.92 MHz
Working temperature	-20°C ~ +70°C	-20°C ~ +70°C
Package weight	10.10Kg	10.18Kg

4. Installation

DKC500AC/DKC800AC sliding gate opener is applicable to gate weight less than 600kg/800kg, and length of the sliding gate less than 8m. The drive mode adopts the rack and gear transmission. This gate opener must be installed inside the enclosure or yard for protection.

4.1 Installation drawing

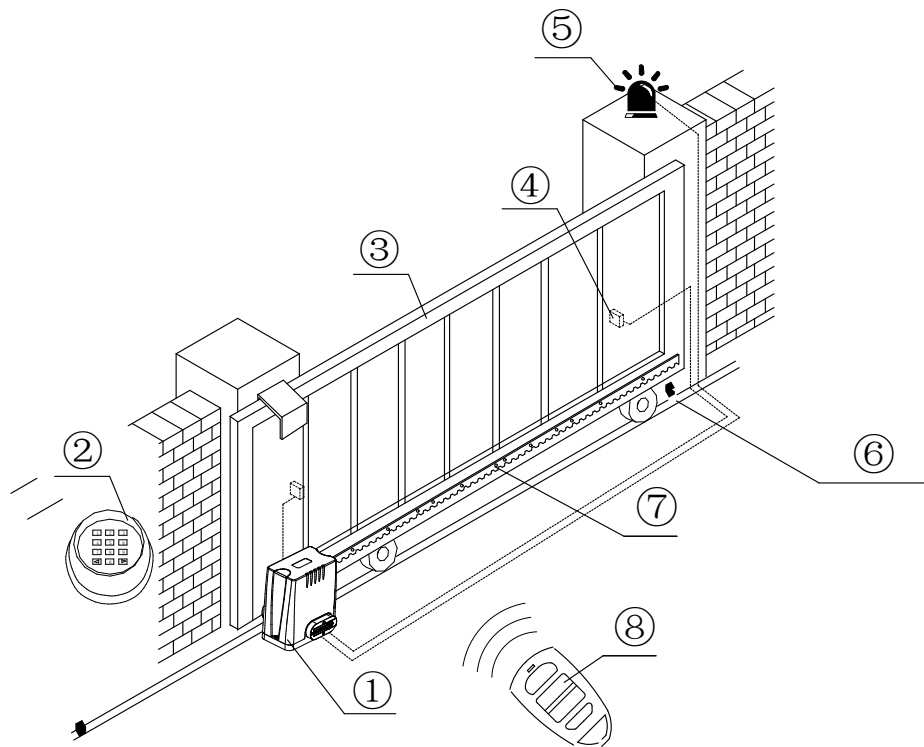

Figure 1

- ① Gate opener; ② Wireless keypad (optional); ③ Gate; ④ Infrared sensor (optional);
⑤ Alarm lamp (optional); ⑥ Safety stop block; ⑦ Gear rack; ⑧ Remote control;

4.2 Size of main engine and accessories

4.2.1 Size of main engine

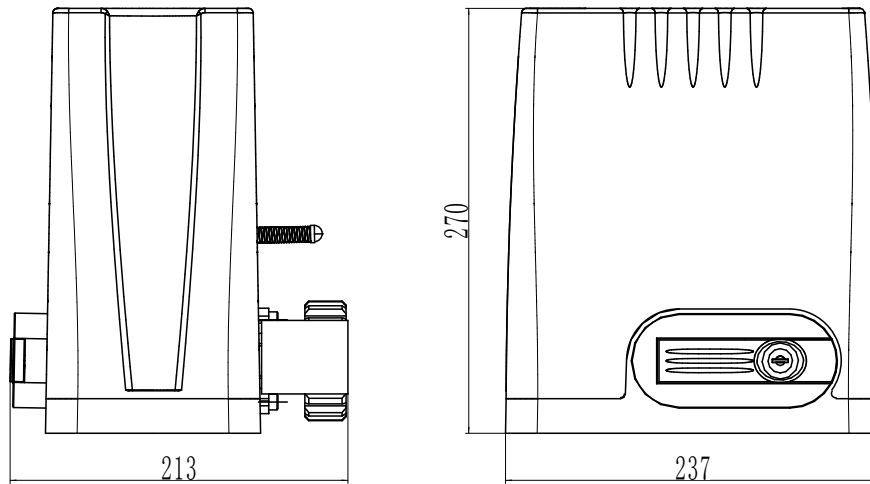

Figure 2

4.2.2 Size of mounting plate

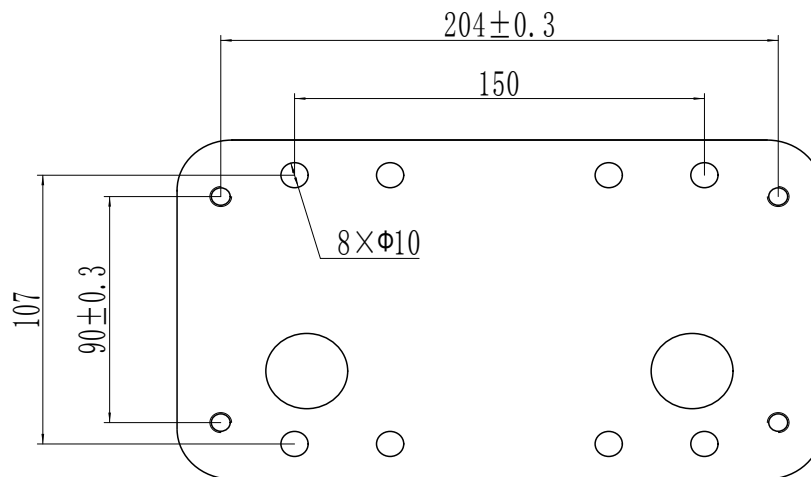

Figure 3

4.3 Installation procedures

4.3.1 Preparation work before installation

Please make sure that the sliding gate is correctly installed, the gate rail is horizontal, and the gate can be manually moved smoothly before installing the gate opener.

Cable installation

In order to guarantee the normal operation of the gate opener and protect the cables from damages, please bury the motor & power cable and controlling cable separately with two PVC tubes.

Concrete pedestal

Please precast a concrete pedestal with the size can be 400mm x 250mm, depth be 200mm in

advance, so as to firmly install DKC500AC/DKC800AC gate opener. **Please make sure the distance between the gate and gate opener is appropriate before casting the pedestal.**

Embedded screws

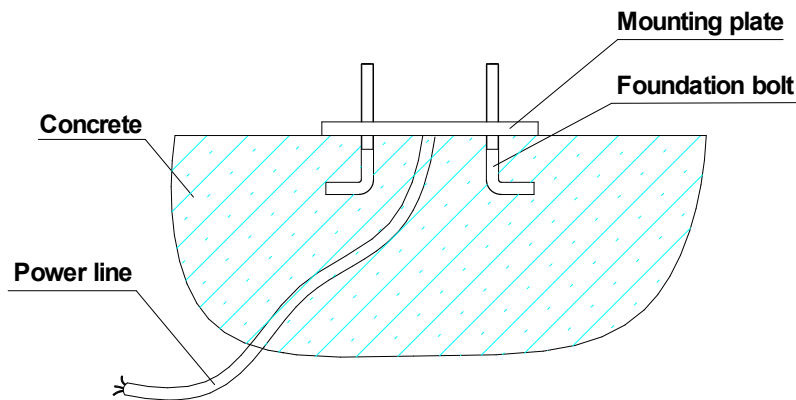

Figure 4

4.3.2 Main engine installation

- Dismantle the plastic housing on the main engine before installation and keep relevant fasteners properly;
- Please prepare the power line for connecting the mounting plate to the main engine (the number of power supply cable cores should not be less than 3 PCS, the sectional area of cable core should be over 1.5mm² and the length should be determined by users according to the situation on installation spot)
- Please unlock the main engine before installation, the unlock method is: insert the key, and open the manual release bar till it rotates by 90° as shown in Figure 5. Then turn the output gear and the gear can be rotated easily;

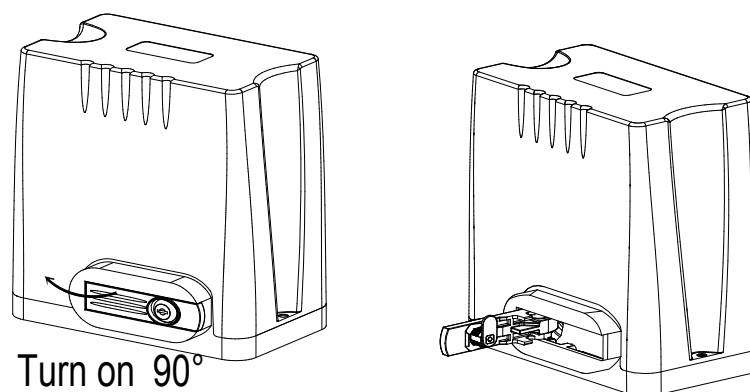

Figure 5

4.3.3 Gear rack installation

- Fix the mounting screws to the rack.
- Put the rack on the output gear, make the rack engage with the output gear then weld the mounting screw to the gate (each screw with one solder joints firstly).

- Manually move the gate (gate should be moved smoothly after motor unlocked) to check whether there is a fit clearance between rack and output gear, as shown in Figure 7.
- Weld all the mounting screws to the gate firmly.
- Make sure that all racks on the same straight line.
- Pull the gate after installed, make sure the entire trip is flexible without any stuck.

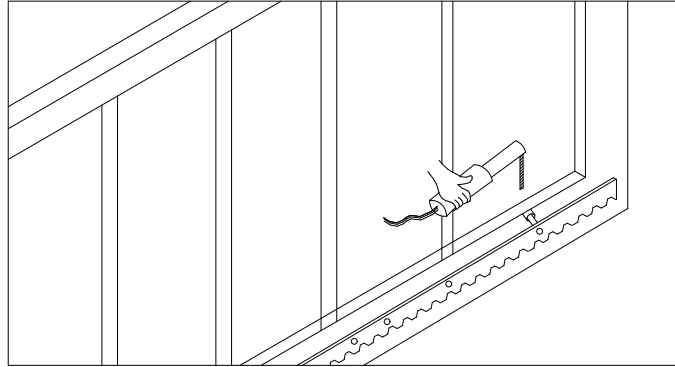

Figure 6

The fit clearance of output gear and rack is shown in Figure 7 below:

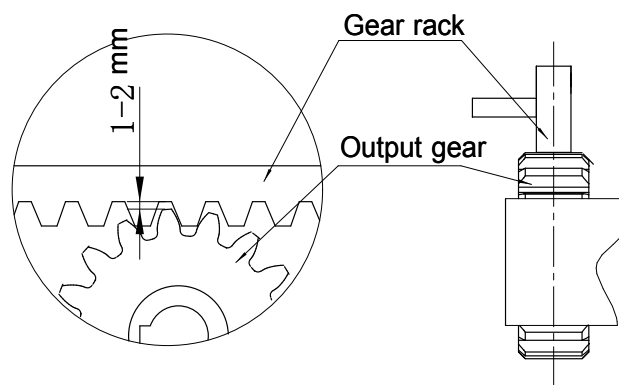

Figure 7



Warnings

- To ensure safety, install safety stop blocks on both ends of the rails to prevent the gate from running out of the rail. Before installing the main engine, make sure that the safety stop blocks are in place and whether it has the function of preventing the gate from running out of the rail or safety range.
- Please make sure that the main engine and its components have good mechanical properties, and the gate can be operated flexibly when manually moved before installing the main engine.
- Please note that for this product, one control can only drive one main engine, otherwise, the control system will be damaged.
- Earth leakage circuit breaker must be installed in where the gate movement can be seen, and the minimum mounting height is 1.5m to avoid being touched by children.
- After installation, please check whether the mechanical property is good or not, whether gate movement after manual unlocking is flexible or not, whether the installation for infrared sensor

(optional) is correct and effective.

4.3.4 Limit switch adjustment

Spring limit switch - The installation position of spring limit switch is shown in Figure 8:

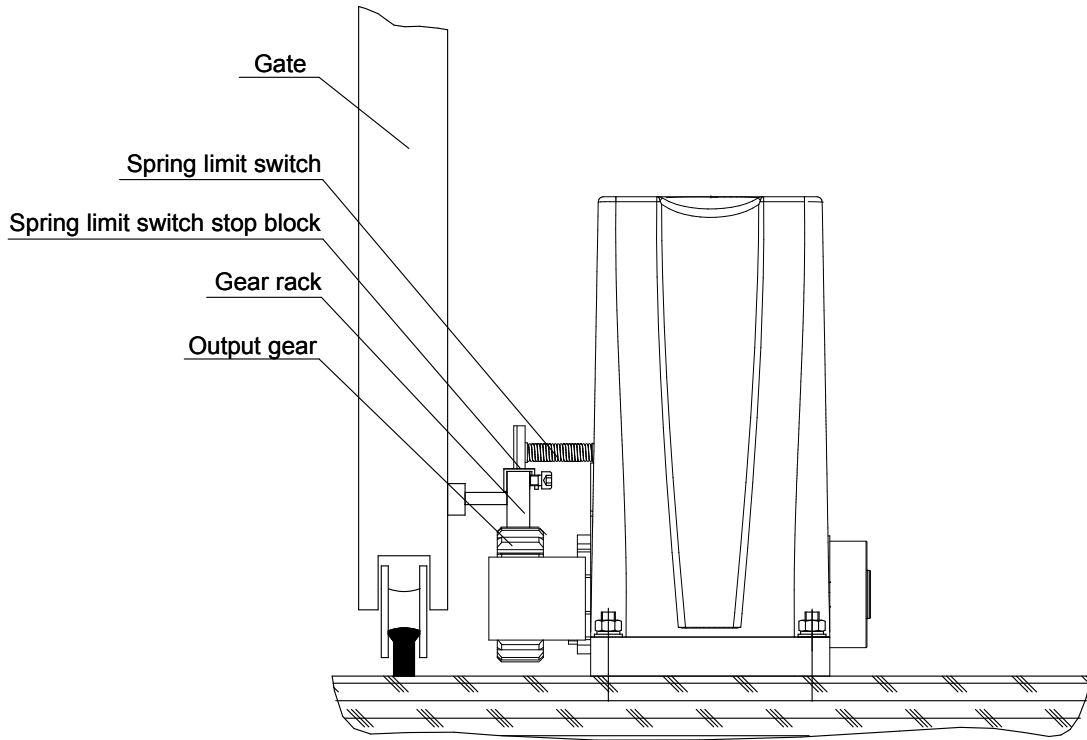

Figure 8

The installation of spring limit switch stop block is shown in Figure 9:

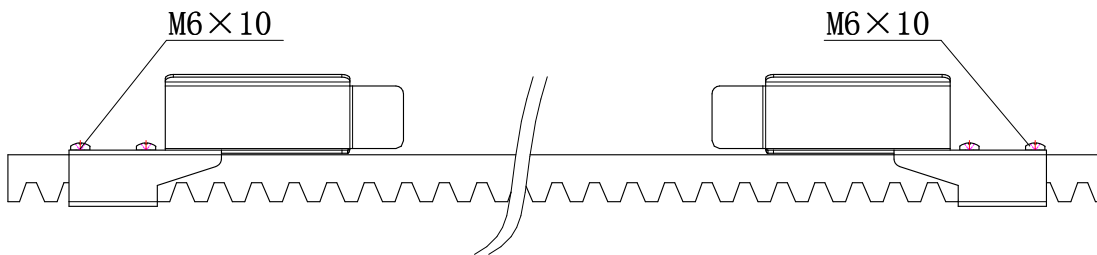

Figure 9

Magnetic limit switch - The installation position of magnetic limit switch is shown in Figure 10:

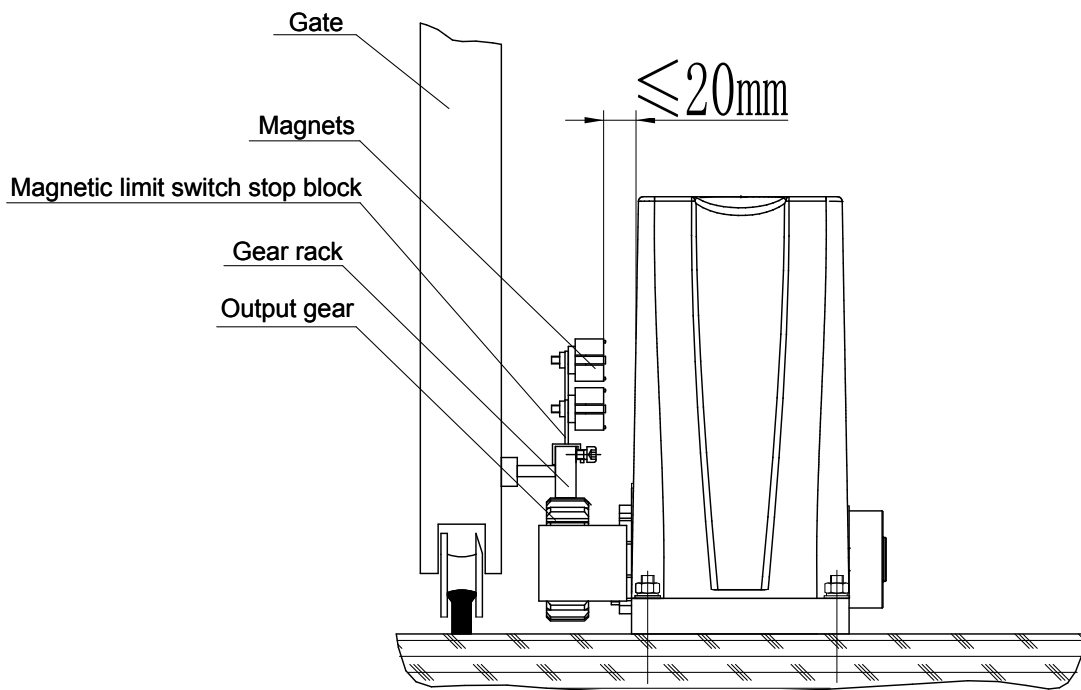

Figure 10

The installation of magnetic limit switch stop block is shown in Figure 11:

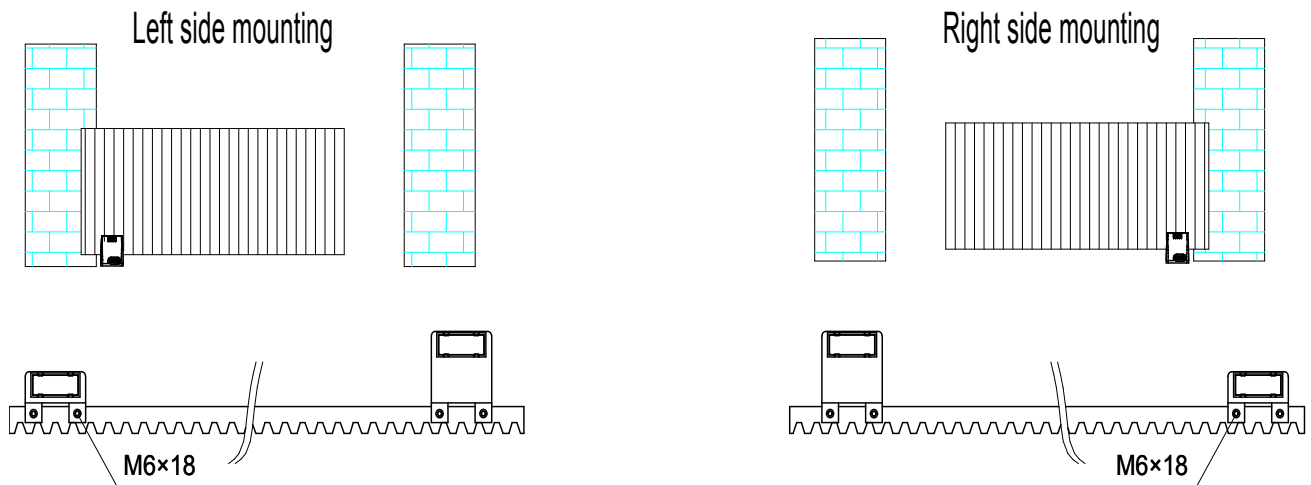

Figure 11

Note: The default setting is right side mounting. (According to actual situation, please refer to the “Note” of section 4.3.5.1 and 4.3.5.2 “Adjustment and operation” to adjust.)

4.3.5 Intelligent control board

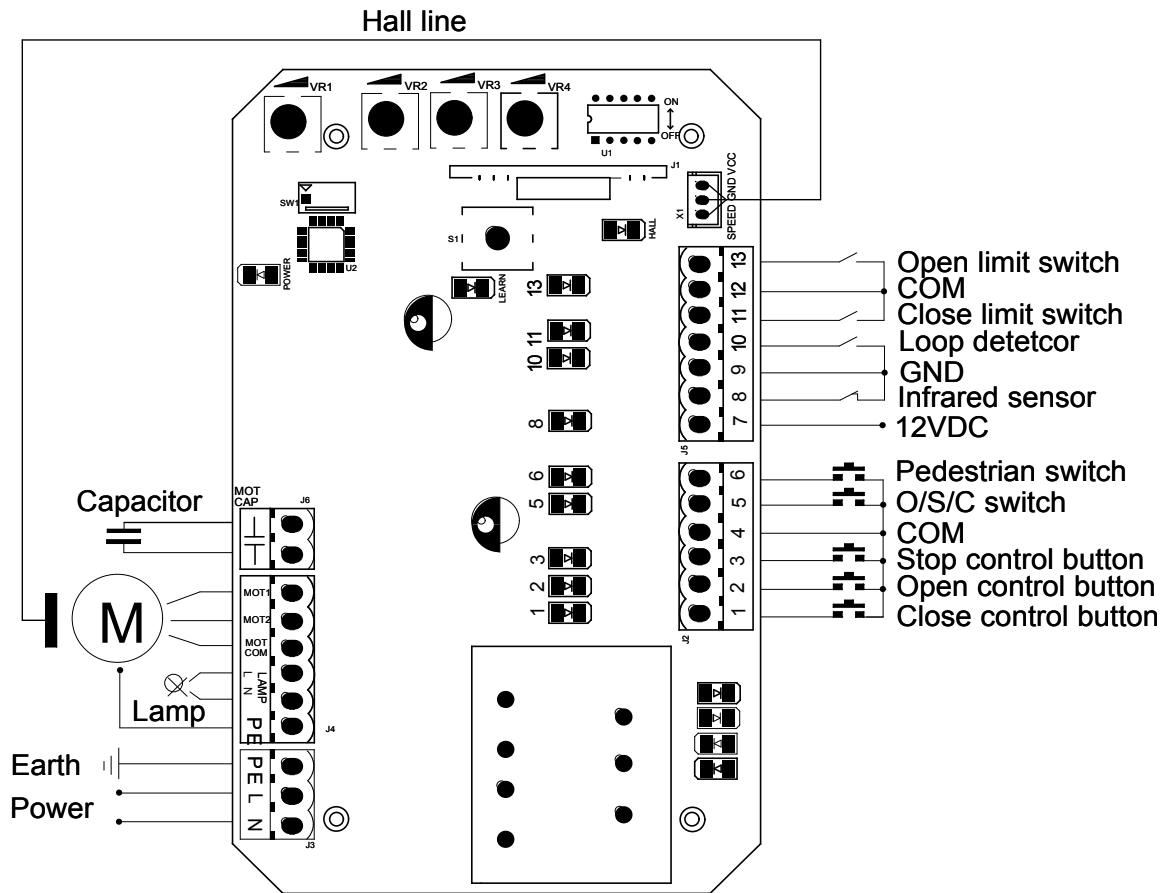

Figure 12

Wiring instruction:

1. Connect L and N to the power supply of AC220V/50HZ; AC110V/60HZ; L is Live wire, N is Neutral wire, and PE is grounding wire.
2. Connect LAMP to caution light; voltage: AC220V/50HZ; AC110V/60HZ.
3. Connect the motor wire MOT2 to the REV motor wire, connect MOT1 to the FWD motor wire, and connect MOTCOM to the motor common wire.
4. Connect MOTCAP to the capacitor wire.

J2 Terminal (For the convenience of wiring, this terminal is accompanied with failure diagnosis light)

1. Gate close control button (N.O.)
2. Gate open control button (N.O.)
3. Stop control button (N.O.)
4. Control button common terminal
5. Open/Stop/Close/Stop loop control button (N.O.)
6. Pedestrian mode control button (N.O.)

Press the button while the door is closed, it will open for 1 meter which is for pedestrian only.

J5 Terminal (For the convenience of wiring, this terminal is accompanied with failure diagnosis

light)

7. Power supply for fittings: +12VDC (Electric current $\leq 100\text{mA}$) ;
8. Photocell input (N.C.); short out the device with terminal 9(GND) if not used.
9. GND
10. Loop detector (sensor coil) connector (N.O.)

In the closing process, once vehicles are detected by the loop detector, the gate will open immediately; when the vehicle passes, the gate will close automatically. When the gate is in a halted state, it will keep this state when vehicles are detected; after the vehicle passes, the gate will close automatically.

In the above loop detector function, users can make the gate close automatically 12 seconds later after the vehicle passes. Change the No.4 key of the dip switch on circuit board, and the gate will close automatically 12 seconds later after the vehicle passes.

11. Close limit switch
12. Limit switch and other input signal common terminal
13. Open limit switch

Function adjustment

Functional parameters of the control board equipped with microprocessor can be adjusted through potentiometer and dip switch, so as to meet different installation requirements.

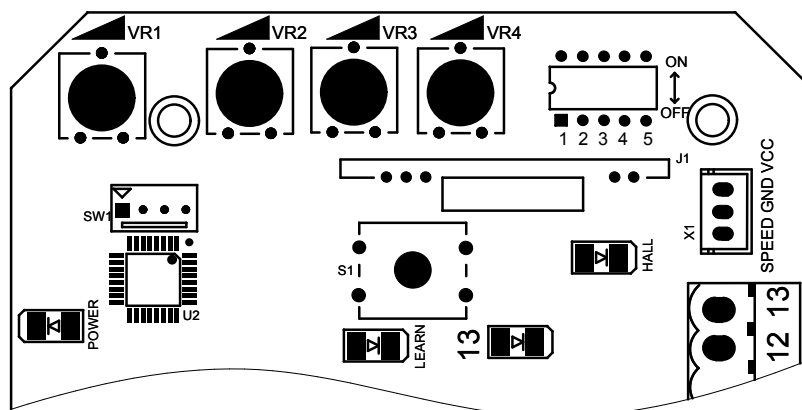

Figure 13

Adjusting knob

VR1: When meet obstacle reverse function is enabled (DIP switch 5 on OFF position and the motor assembled with the hall line). This knob is used for sensitivity adjustment of meet obstacle. Clockwise rotation to reduce sensitivity of obstacle, counter-clockwise rotation to increase sensitivity of obstacle.

When meet obstacle reverse function is disabled (DIP switch 5 on ON position). This knob is used for motor working total time adjustment. Clockwise rotation to increase, counter-clockwise rotation to reduce. The total time can be set to 10 seconds as minimum and 90 seconds as maximum.

VR2: For brake force adjustment in limit position.
Clockwise rotation to increase, counter-clockwise rotation to reduce.
Rotate to the minimum to cancel brake function in place.

VR3: For slow stop width adjustment.
Clockwise rotation to increase, counter-clockwise rotation to reduce.

Rotate to the minimum to cancel the slow stop function.

VR4: For motor output force adjustment to keep safe usage.

Clockwise rotation to increase, counter-clockwise rotation to reduce.

Note: The default setting is VR1, VR2, VR3, VR4 are the maximum value, and the user can adjust according to the actual requirement.

Warning: The motor output force cannot set too large, just to be able to drive the gate.

Dip switch

1. Soft start function. OFF - enabled; ON - disabled.
2. Limit switch setting. OFF- normal open (N.O.); ON - normal close (N.C.).
3. Automatic close time.
4. Automatic close time.

Setting for automatic close time:

3 OFF 4 ON: automatic close time is 12s,

3 ON 4 OFF: automatic close time is 24s,

3 ON 4 ON: automatic close time is 36s,

3 OFF 4 OFF: no automatic close function.

5. Meet obstacle reversal function. OFF - enabled; ON - disabled.

Infrared connection

Infrared photocell function: In the closing process, when infrared ray of the photocell is covered by people or objects during its detection range, the gate will open immediately for security protection.

The distance between photocell receiver and photocell emitter should be more than 2 meters, otherwise will affect the induction of the photocell.

If connect the infrared photocell, please remove the short connection between 8 and 9 on the J5 terminal.

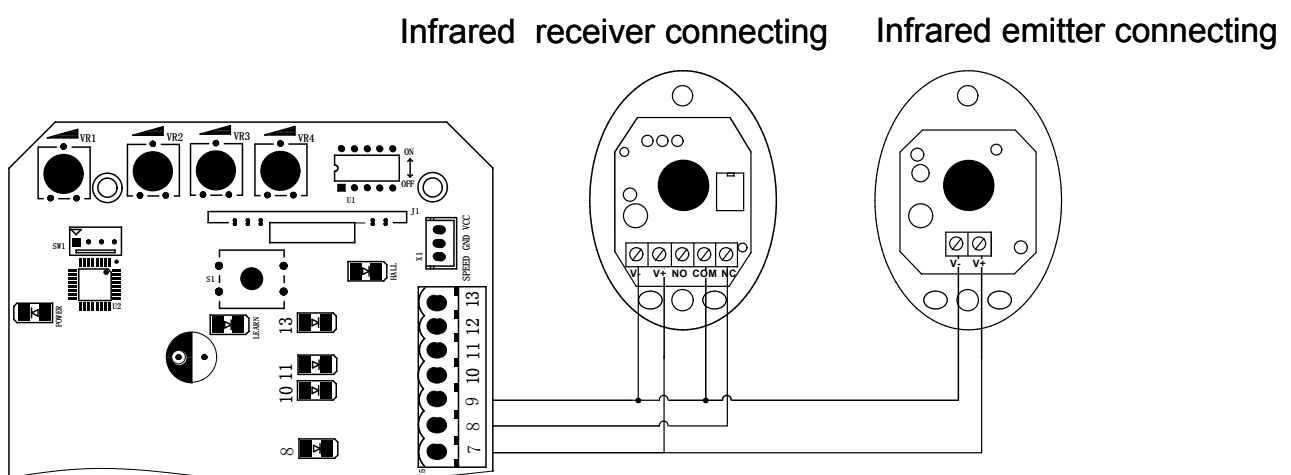

Figure 14

Adjustment and operation

Remote control operation

Three button mode remote control: OPEN/CLOSE/STOP of main engine are controlled by three buttons separately on the remote control.

Single button mode remote control: OPEN/CLOSE/STOP of main engine are controlled by one button circularly on the remote control.

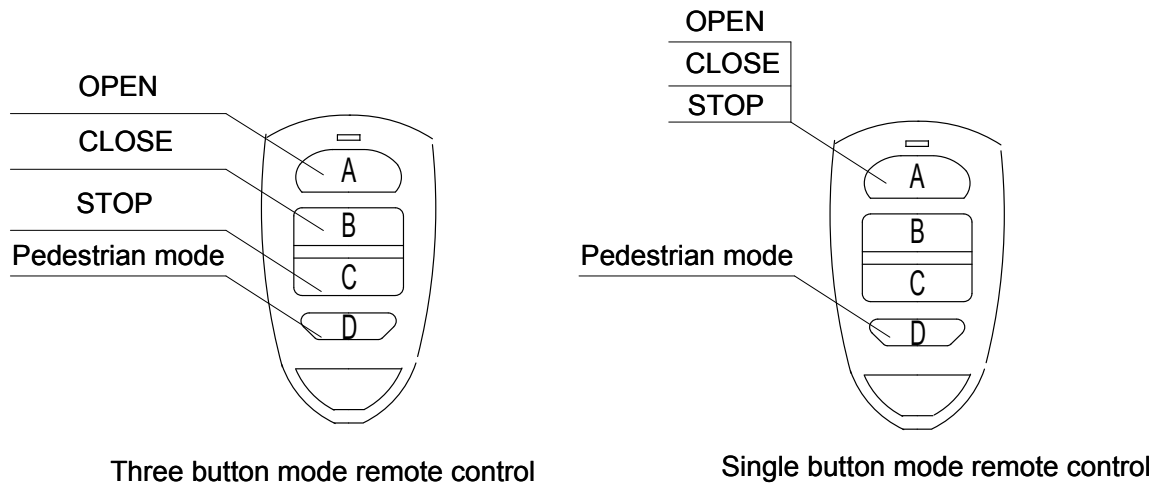

Figure 15

Add extra remote control (remote control learning): Remove the main engine housing, then take out the upper cover of the control box, press and hold the learning button S1 for 2 seconds, then the indicator light LEARN will be on; press the button that to be learned on the remote control twice, the LEARN will flash several times and be off; remote control learning complete. A maximum of 40 remote controls can be learned.

Delete remote control: To delete remote control that have been learned; press and hold the learning button S1, the indicator light LEARN will be on; Then release it until LEARN is off. After the steps, all the matched remote controls will be deleted.

The fourth button on the remote control is for pedestrian mode, press the button while the door is closed, it will open for 1 meter which is for pedestrian only.

Note: To disengage gate opener, move the gate to the middle position, then close the clutch and press the open button of external button switch to open the gate. **If the gate opening direction is wrong, you can exchange the motor phase-sequence lines MOT2 and MOT1. If the opening or closing limit is wrong, please exchange limit switch lines which are connected to the corresponding terminal 11 and 13 on the control board.**

5. Others

5.1 Maintenance

Check whether the gate operates normally every month.

For the sake of safety, each gate is suggested to be equipped with infrared protector, and regular inspection is required.

Before installation and operation of the gate opener, please read all instructions carefully.

Our company reverses the right to change the instruction without prior notice.

5.2 Troubleshooting

Problems	Possible Reasons	Solutions
The gate cannot open or close normally, and LED does not light.	<ol style="list-style-type: none"> 1.The power is off. 2.Fuse is burned. 3.Control board power wiring with problem. 	<ol style="list-style-type: none"> 1.Switch on the power supply. 2.Check the fuse (code FU), change the fuse if burnt. 3.Re wiring according to instructions.
The gate can open but cannot close.	<ol style="list-style-type: none"> 1.Photocell wiring with problem. 2.Photocell mounting with problem. 3.Photocell is blocked by objects. 4.Sensitivity of obstacle is too high (Intelligent type). 5.Hall switch parts is damaged (Intelligent type). 	<ol style="list-style-type: none"> 1.If not connect photocell, please make sure that the infrared port and GND short circuit; if connect infrared sensor, please make sure the wiring is correct and the photocell is N.C. 2.Make sure that the photocell mounting position can be mutually aligned. 3.Remove the obstacle. 4.Reduce the sensitivity of obstacle. 5.Change hall switch parts.
Remote control doesn't work.	<ol style="list-style-type: none"> 1.Battery level of the remote control is low. 2.Remote control learning is not completed. 	<ol style="list-style-type: none"> 1.Change the remote control battery. 2.Re-conduct remote control learning.
Press OPEN, CLOSE button, the gate is not moving, motor has noise.	<ol style="list-style-type: none"> 1.Capacitor is broken. 2.Capacitor is poor connected. 3.Gate moving is not smoothly. 	<ol style="list-style-type: none"> 1.Change capacitor. 2.Check the capacitor wiring. 3.According to the actual situation to adjust the motor or the gate.
Not stop at the limit position when opening / closing.	<ol style="list-style-type: none"> 1. The limit direction is wrong. 2. The mounting of magnetic limit switch with problem. 	<ol style="list-style-type: none"> 1.Check whether the limit switch wiring is consistent with the actual direction of operation. 2. Check whether the distance between magnetic limit switch and motor, and the height of the magnetic limit switch can reach up the mounting requirement.

Leakage switch tripped.	Power supply line short circuit or motor line short circuit.	Check wiring.
Remote control working distance is too short.	Signal is blocked.	Connect external receiver antenna, 1.5 meters above ground.
The gate moves to the middle position to stop or reverse.	1.Motor output force is not enough. 2.Gate meets obstacle.	1.Adjust the VR4. 2.Remove the obstacle.
Gate opens automatically	Automatic close function has been turned on but with incorrect opening direction.	Please refer to the attentions under 4.3.5.1 and 4.3.5.2 to change the opening direction.

Warranty

Warranty Ordinance

1. To repair against this warranty card and invoice during the warranty period.
2. Warranty period: 1 year after the date of invoice.
3. Without unauthorized dismantling, any product broken or damage due to quality problem, we'll offer the repair service for free or replace for free.
4. The malfunction and damaged caused by incorrect use or man fault is not covered by this warranty.

Maintenance Record

Check Date	Check Content	Maintained by